

OACIS

Open Architecture Control Integrated System

Timing Sequence

Version 05.00.01



www.atainc.com

ata@atainc.com

All Rights Reserved

CONTENTS

I.	INITIALIZE OACIS (Turning on the OACIS)	4
II.	REMOTE PROGRAM CALL	6
III.	REMOTE PROGRAM START -> END.....	7
IV.	REMOTE PROGRAM START -> PAUSE or STOP -> RESUME -> END ..	8
V.	REMOTE PROGRAM START -> E STOP -> RESET	9
VI.	REMOTE PROGRAM START -> SOFT STOP -> RESET	10
VII.	REMOTE PROGRAM START -> ERROR -> RESET	11
VIII.	REMOTE HOMING	12
IX.	REMOTE JOG BY DIGITAL INPUT.....	13
X.	READY -> E STOP -> AUTO RESET -> READY	14

 **RETURN HOME BY DI SIGNAL AFTER JOG
MOVING WILL MAKE ERROR HAPPEN
FOR SAFETY REASON.**

Normal sequence,

Home OK & Ready On → Jog Moving by PC command or
PLC → Reset → Return Home by DI signal

I. INITIALIZE OACIS (Turning on the OACIS)

A. Whenever you power on the OACIS, it is to be initialized by itself. While initializing process, it uploads the last used program and configuration. Then it becomes one of below status.

- Error Condition (Ready Off / Error On)

SYSTEM	DIO		AXIS 1
Prog. Start	I#01	O#01	Servo Enable
Prog. Stop	I#02	O#02	Tare Torque
Return Home	I#03	O#03	Reset Alarm
Reset	I#04	O#04	Servo Ok
E-Stop	I#05	O#05	CW Limit
Home	I#06	O#06	CCW Limit
Prog. Home	I#07	O#07	Home Sensor
Ready	I#08	O#08	Pos. Limit
Error	I#09	O#09	Neg. Limit
Prog. End	I#10	O#10	Brake
Status Bin	I#11	O#11	Z Pulse
0	I#12	O#12	
Prog. Set In	I#13	O#13	
0	I#14	O#14	
Prog. Set Out			
1			
Strobe			

➤ You need to do reset "Error" and Return Home.

- Homing Required #1 Condition (Ready Off / Error Off)

SYSTEM	DIO		AXIS 1
Prog. Start	I#01	O#01	Servo Enable
Prog. Stop	I#02	O#02	Tare Torque
Return Home	I#03	O#03	Reset Alarm
Reset	I#04	O#04	Servo Ok
E-Stop	I#05	O#05	CW Limit
Home	I#06	O#06	CCW Limit
Prog. Home	I#07	O#07	Home Sensor
Ready	I#08	O#08	Pos. Limit
Error	I#09	O#09	Neg. Limit
Prog. End	I#10	O#10	Brake
Status Bin	I#11	O#11	Z Pulse
0	I#12	O#12	
Prog. Set In	I#13	O#13	
0	I#14	O#14	
Prog. Set Out			
1			
Strobe			

➤ You need to do Return Home.

- If it returned to home position successfully, you can see “Error” Off, “Home Ok” On and “Ready” On.

SYSTEM	DIO		AXIS 1
Prog. Start	I#01	O#01	Servo Enable
Prog. Stop	I#02	O#02	Tare Torque
Return Home	I#03	O#03	Reset Alarm
Reset	I#04	O#04	Servo Ok
E-Stop	I#05	O#05	CW Limit
Home	I#06	O#06	CCW Limit
Prog. Home	I#07	O#07	Home Sensor
Ready	I#08	O#08	Pos. Limit
Error	I#09	O#09	Neg. Limit
Prog. End	I#10	O#10	Brake
Status Bin	I#11	O#11	Z Pulse
0	I#12	O#12	
Prog. Set In	I#13	O#13	
0	I#14	O#14	
Prog. Set Out			
1			
Strobe			

II. REMOTE PROGRAM CALL

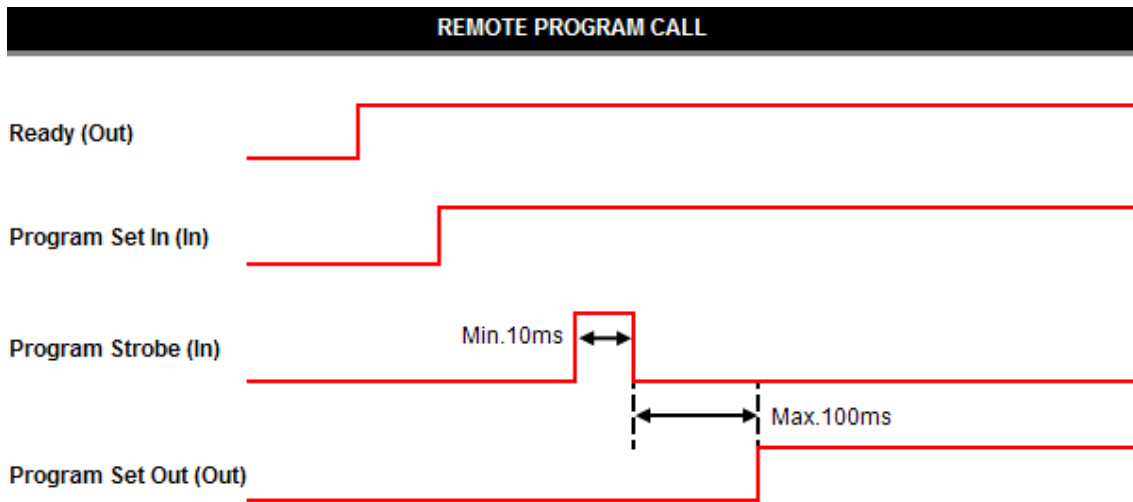

- A. Note #1: Minimum Time Delay is 50ms between Input and Output.

III. REMOTE PROGRAM START -> END

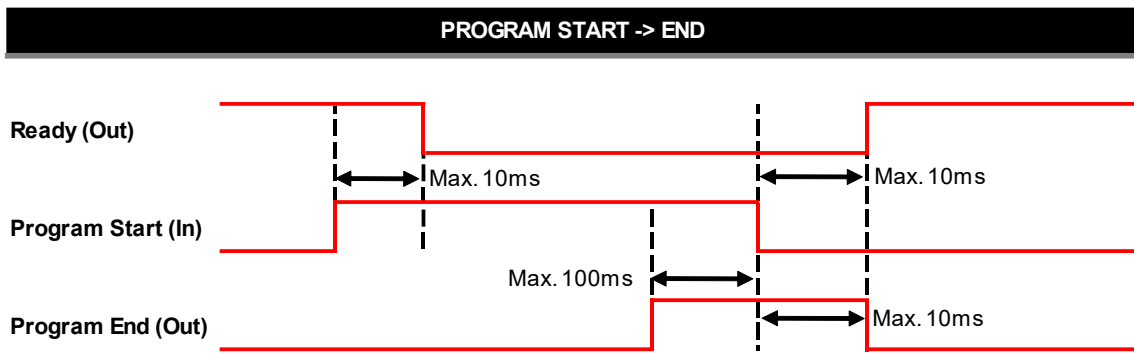

*Axes need to be at Home or Program Home position to turn on Ready Signal on cycle completion.

- A. Note #1: Minimum Time Delay is 50ms between Input and Output.
- B. There are two options to start a program by REMOTE Command like PLC. You can specify the option by setting the user configuration below on the Admin window.

35	Program End Time Delay	0
36	Program Start Mode	0
37	Tare Axes Load After Homing (0:...	0

- **0 (Handshake):** Program Start should be kept On until Program End signal becomes turned On. Or an error will occur.
- **1 (Pulse):** A program keeps running until Program End with an only rising edge of Program Start Input Pulse.

- C. You can also run a program by using the PC Command below.

The screenshot shows a 'Command' window with several tabs: OPERATING, JOG, SET DO, MISC, and REALTIME. The 'OPERATING' tab is active, displaying a row of control buttons: RUN PROGRAM (circled in red), RUN STEP, PAUSE, STOP, SOFT-STOP, HOMING, and RESET. Below the buttons, a legend explains the functions:

- RUN PROGRAM: RUN CURRENT PROGRAM
- RUN STEP: RUN CURRENT STEP
- PAUSE: PAUSE RUNNING ON COMPLETING CURRENT STEP AND WILL BE RESUMED BY "RUN PROGRAM"
- STOP: STOP RUNNING ON COMPLETING CURRENT STEP TEHN PROGRAM END
- SOFT-STOP: STOP RUNNING PROGRAM IMMEDIATELY
- HOMING: RETURN HOME ALL AXES
- RESET: RESET ERRORS

TIMING SEQUENCE

IV. REMOTE PROGRAM START -> PAUSE or STOP -> RESUME -> END

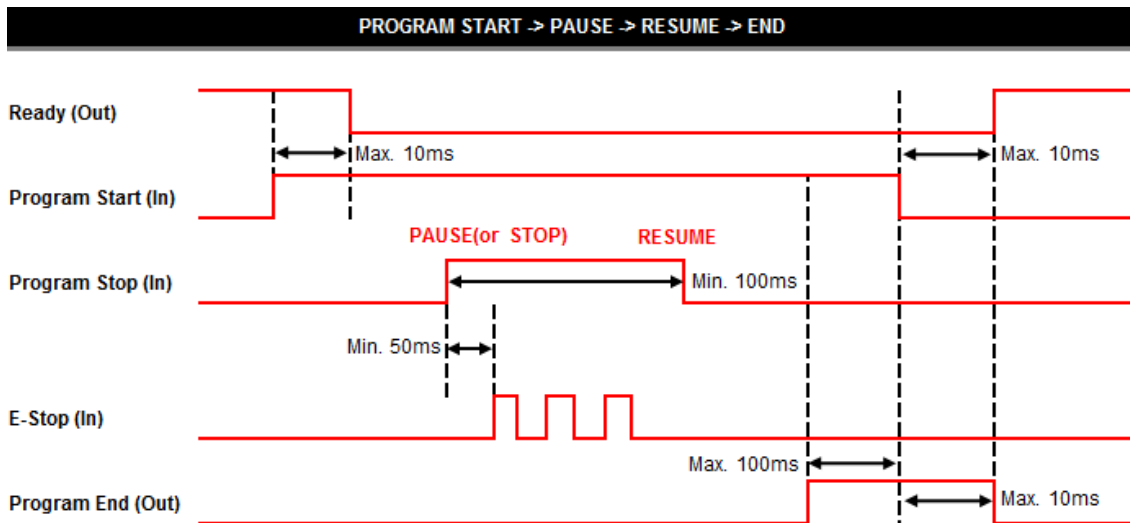

*Axes need to be at Home or Program Home position to turn on Ready Signal on cycle completion.

- A. Note #1: Minimum Time Delay is 50ms between Input and Output.
- B. Note #2: Minimum Time Delay is 100ms between Pause(or Stop) and Resume.
- C. This timing sequence shows how to pause the program before program end. You can use this timing sequence to mute "E-Stop" as well.
- D. There are two options. You can specify the option by setting the user configuration below on the Admin window.

33	Home Signal Priority	0
34	Stop Option	0
35	Program End Time Delay	0
36	Program Start Mode	0

- **0 (Pause):** When you set "Program Stop" as ON at the specific step, OACIS holds the Axis at the position as soon as completing the step. Then, it moves on to next step by "Program Stop" as Off (Resume).
- **1 (Stop):** OACIS holds the Axis as soon as "Program Stop" On. And it runs the uncompleted step again with "Program Stop" off (Resume).
- **2 (Stop, with Motor Drive Reset):** This option is the same as Option 1, but it resets the motor drive before restarting. For example, this option can be used when using a program stop instead of an E-stop in the STO (Safe Torque Off) safety circuit.

Note: Even though "E-Stop" signal comes in while "Program Stop" On, OACIS does not fall into error condition. ("E-Stop" is muted by the "Stop" signal).

⚠ CAUTION: Do not use "Program Stop" signal for safety purpose. It may cause severe problems depending on your system.

V. REMOTE PROGRAM START -> E STOP -> RESET

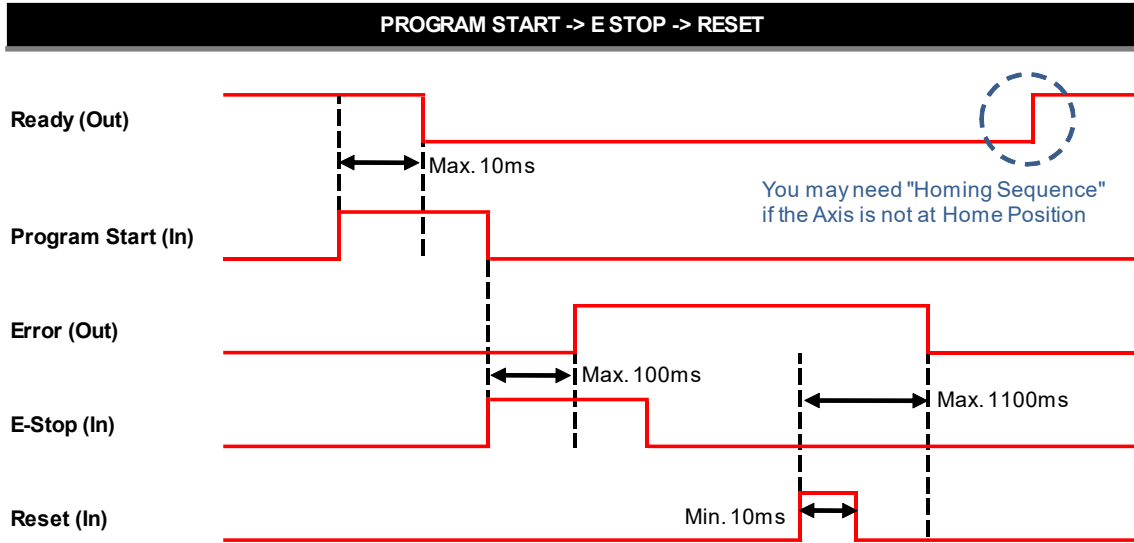

- A. Note #1: Minimum Time Delay is 50ms between Input and Output.
- B. Normally, You need to do "Return Home" after Reset.
- C. If you can't reset "Error" with Reset command, you need to eliminate cause of "Error" first.
- D. You can also reset "Error" by using the below PC Command.

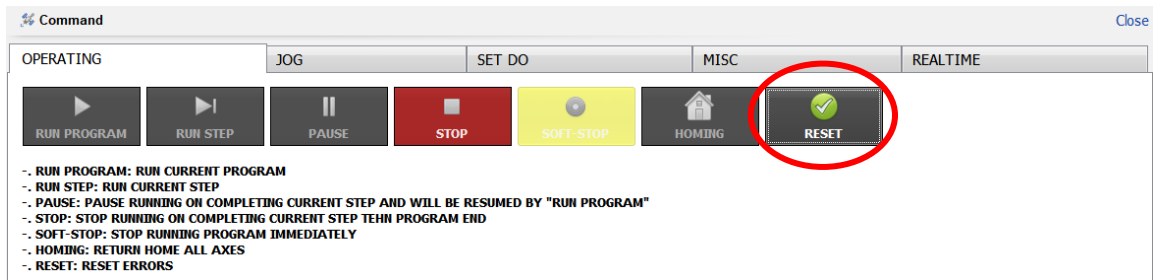

TIMING SEQUENCE

VI. REMOTE PROGRAM START -> SOFT STOP -> RESET

PROGRAM START -> PROGRAM START OFF (Soft Stop) -> ERROR -> RESET

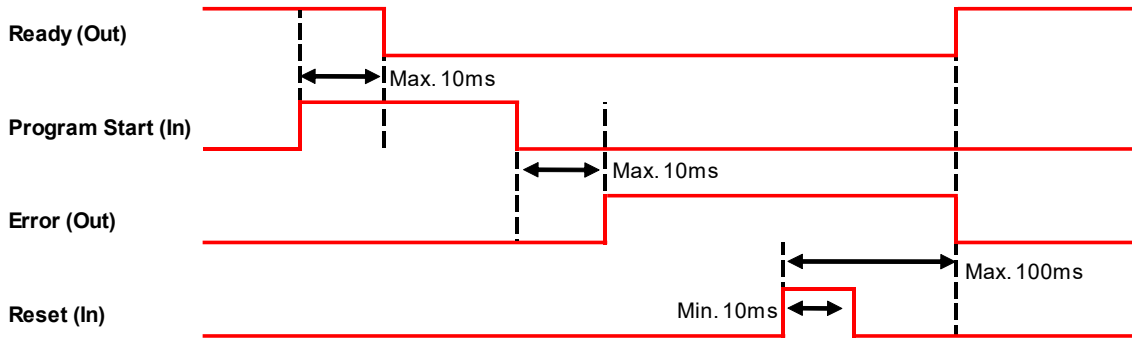

- A. Note #1: Minimum Time Delay is 50ms between Input and Output.
- B. Normally, you need to do "Return Home" after Reset.
- C. If you can't reset "Error" with Reset command, you need to eliminate cause of "Error" first.
- D. You can also reset "Error" by using the below PC Command.
- E. You can also soft-stop by using the below PC Command.

TIMING SEQUENCE

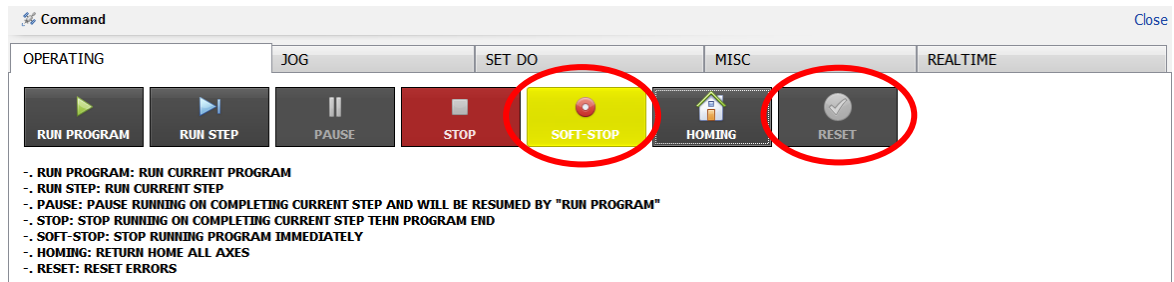

VII. REMOTE PROGRAM START -> ERROR -> RESET

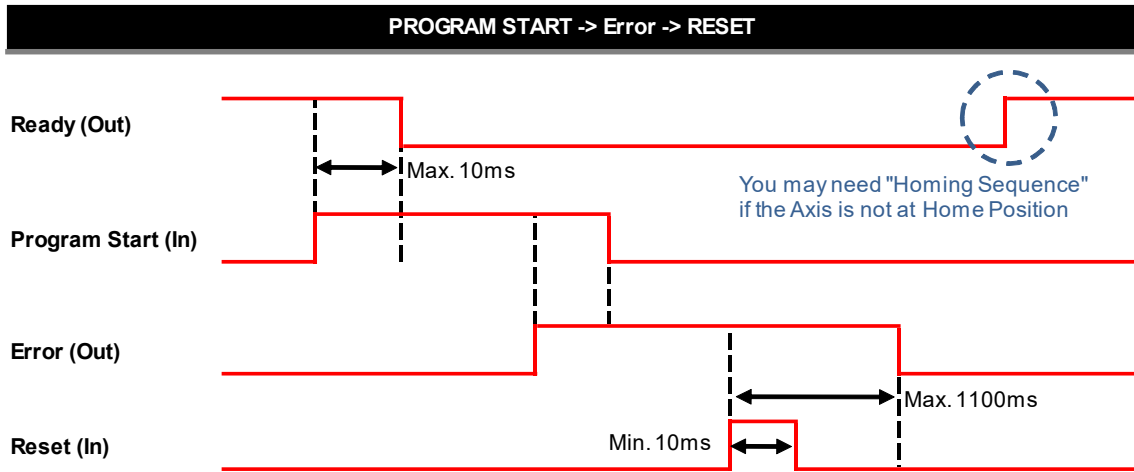

- A. Note #1: Minimum Time Delay is 50ms between Input and Output.
- B. Normally, you need to do "Return Home" after Reset.
- C. If you can't reset "Error" with Reset command, you need to eliminate cause of "Error" first.
- D. You can also reset "Error" by using the below PC Command.

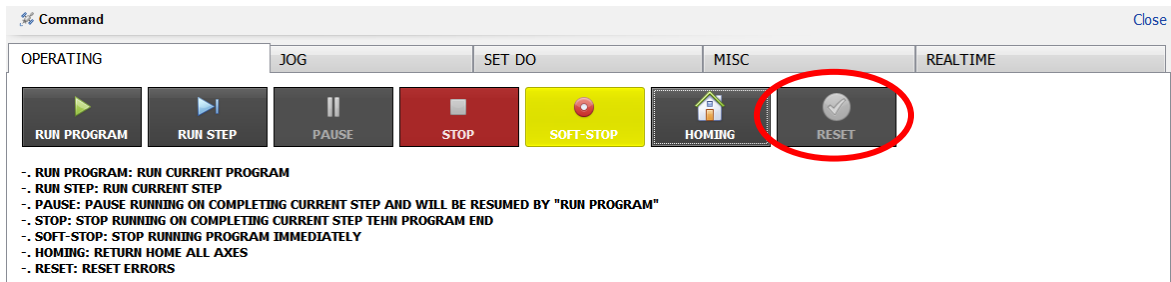

VIII.REMOTE HOMING

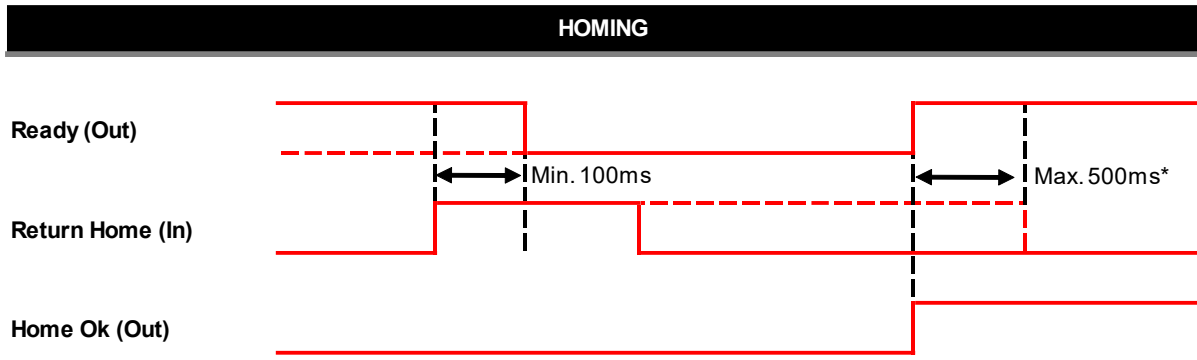

Note*: If this time span is longer than 500ms, OACIS will do Homing Sequence again.

A. You can also do "Homing" by using the below PC Command.

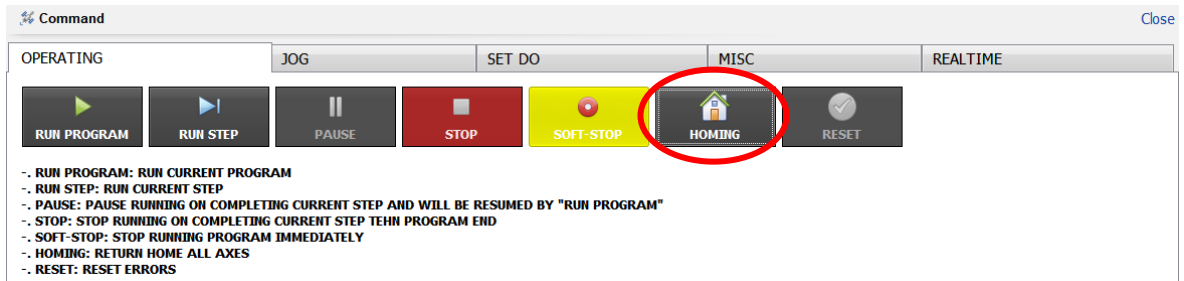

TIMING SEQUENCE

IX. REMOTE JOG BY DIGITAL INPUT

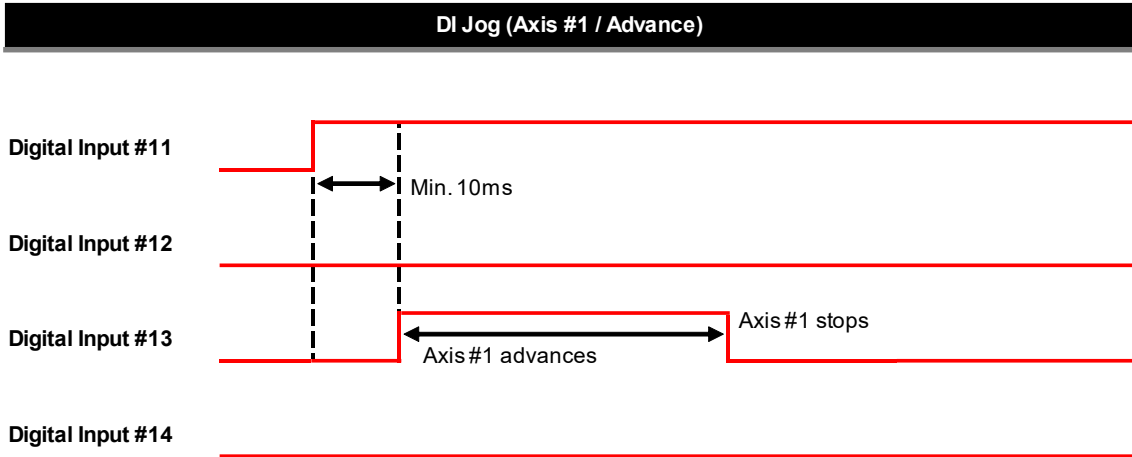

Note:

Axis Selection: DI #11 and #12 (#11: Axis 1 / #12: Axis 2)

Advance: DI #13

Retract: DI #14.

See the manual "How to Configure" for more details.

A. You can also do "Jog" by using the below PC Command.

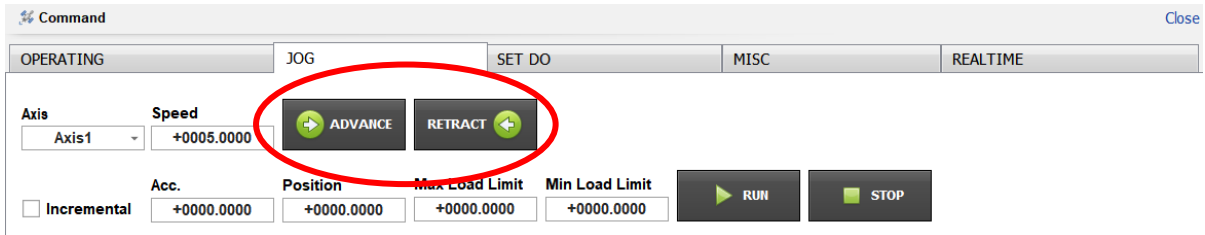

TIMING SEQUENCE

X. READY -> E STOP -> AUTO RESET -> READY

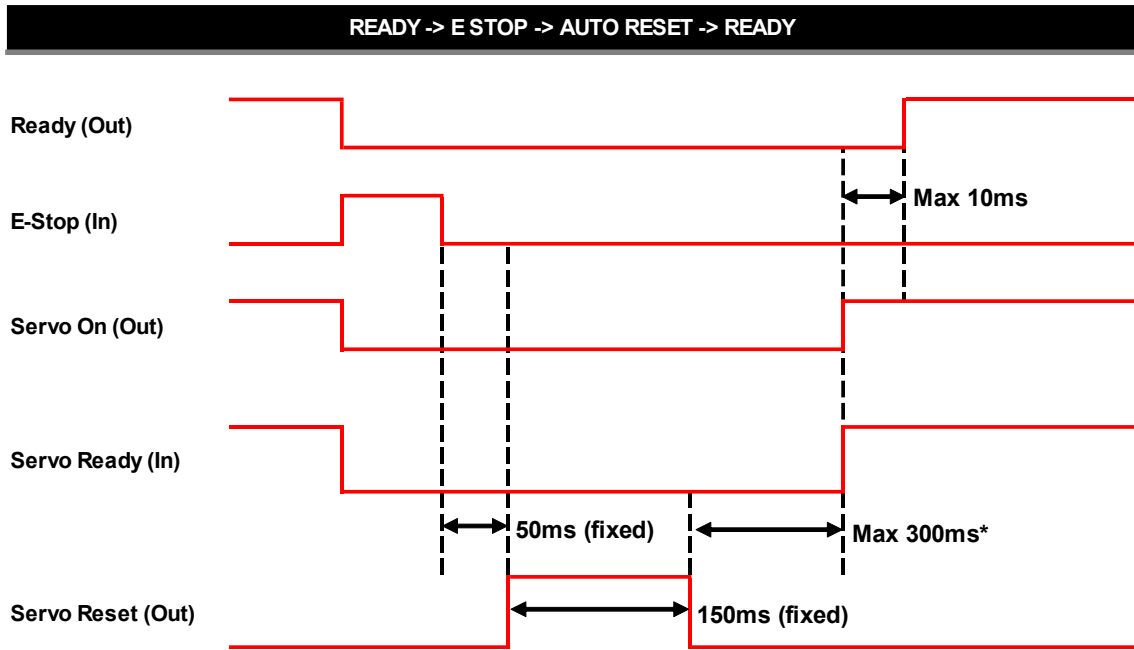

Note*: OACIS sets "Servo Reset" signal on and wait for 300ms until Servo Ready signal gets on. If Servo fails to be Ready, OACIS shows Servo Error.

TIMING SEQUENCE